

NOTE
 Eccentricità max. 0.3 mm.
 Conicità massima ammissibile (A-C) su ogni rullo deve essere 0.55 mm

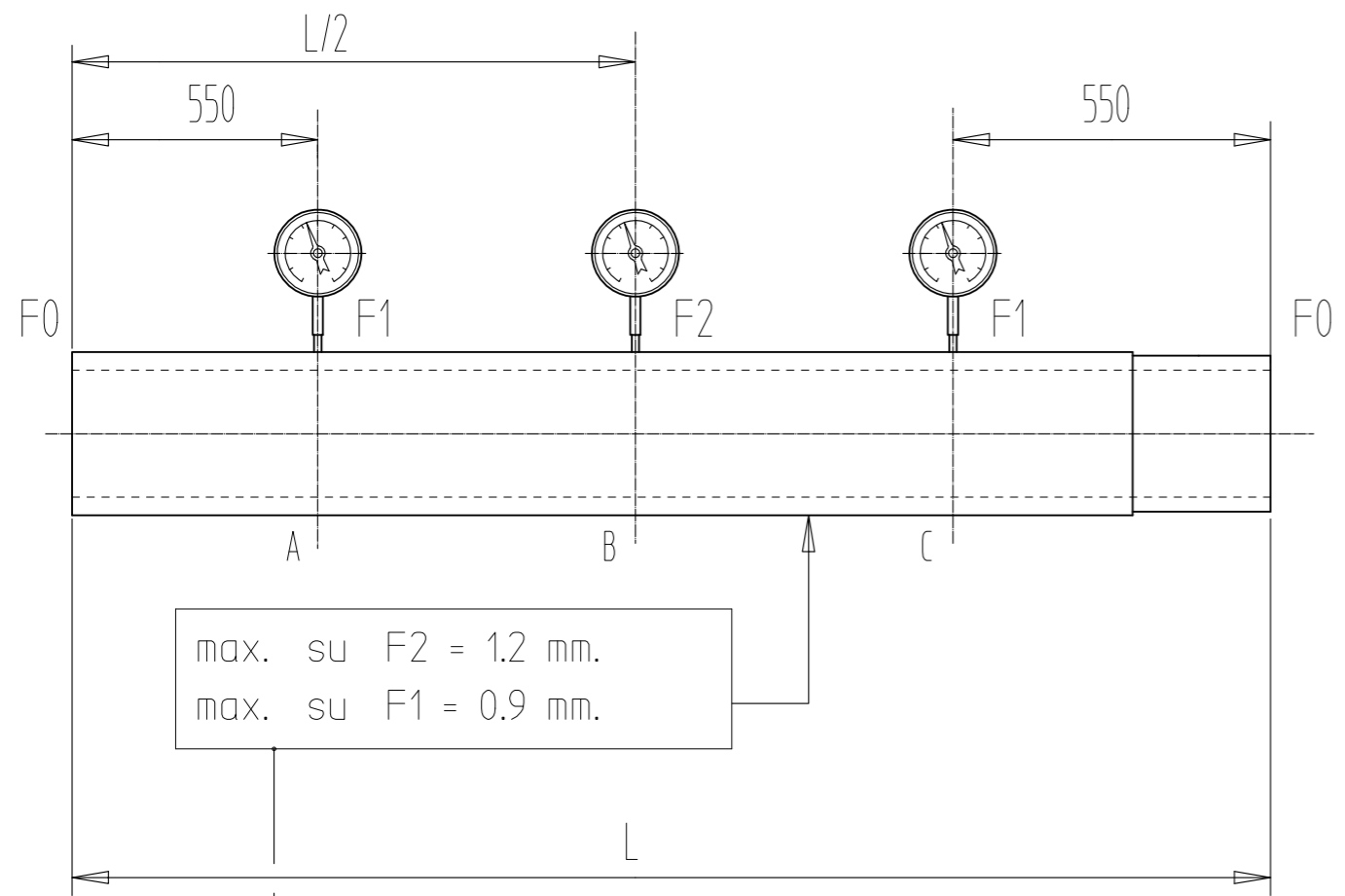

max. su F2 = 1.2 mm.
 max. su F1 = 0.9 mm.

Tolleranza misurata in rotazione

L3320 Ø50/40